

Hydraulic Machine Vise

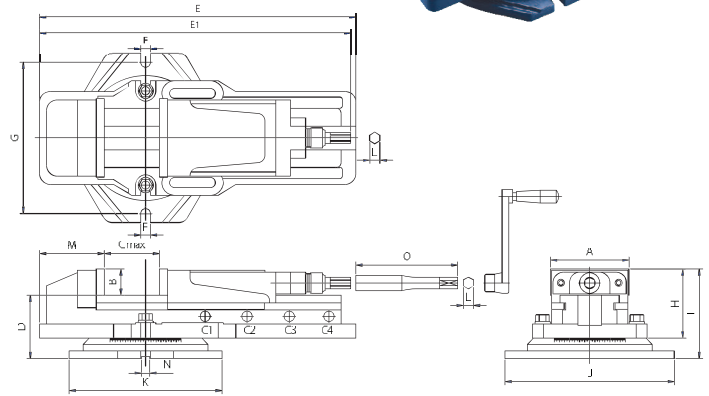

PAT NO. 98202966

- New design: Adjustable pressure device.
- Suit for processing of brass, AL, plastic, steel.



- New design: lock proof system: prevent wrong clamping force sticks the vise.
- Ruggedly constructed for milling, drilling, shaping, grinding and many other machine shop applications.
- Sliding bed ways flame hardened and ground.
- Concealed spindle for protection against chips and dirt.
- Hydraulic-booster system for maximum clamping pressure with minimum force.
- Quick of clamping & locking and easy of operation.
- Accuracy within 0.02mm.
- Furnished with or without swivel base.
- Hydraulic-booster system is guaranteed for using 1 years limited.
- The hydraulic oil number is #68.
- For Hydraulic-booster trouble shooting, please see manual.

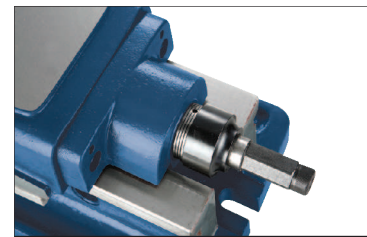

Hydraulic controller: provide stable pressure, hydro indexer.

Order No. & Dimensions

Unit:mm

ORDER NO.	A	B	C max	Opening Size For Capacity				D	E	E1	F	G	H	I	J	K	L	M	N	O	Max. Clamp Forc (kgs)	G.W. (kgs)	CFT (cm)	CODE NO.
				C1	C2	C3	C4																	
NEW VH-4	108	36	175	0-63	55-120	112-175		98	443	583	14	235	95	135	270	240	14	110	16	156	2500	28	45x25x16	1002-001
VH-5	132	48	210	0-75	72-150	146-210		113	550	703	17	253	118	161	290	263	19	124	16	165	4500	47	56x28x18	1002-002
VH-6	151	52	300	0-100	97-200	197-300		124	620	800	19	298	136	176	332	300	19	126	16	200	4500	63	65x34x22	1002-003
VH-8	204	62	300	0-100	94-200	194-300		144	680	857	17	342	162	206	375	350	19	155	16	200	7500	110	71x38x25	1002-004
VH-8L	204	62	400	0-100	94-200	194-300	295-400	144	795	950	17	342	162	206	375	350	19	155	16	200	7500	125	88x41x25	1002-005
VH-12	305	72	375	0-75	70-175	170-275	270-375	144	795	950	17	342	162	206	375	350	19	170	16	200	7500			1002-006

CLAMPING CAPACITY (3 STEPS CLAMPING POSITION FIG)

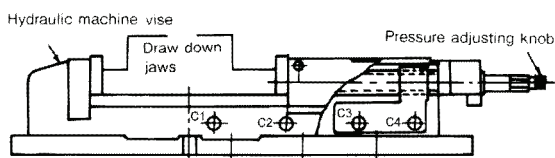

Swivel base

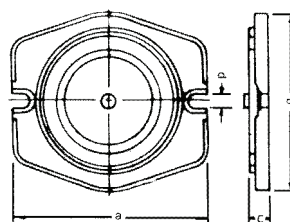

Swivel base Unit:mm

ORDER NO.	a	b	c	d	G.W. (kg)	CODE NO.
HS-4	280	210	28	16	4	1002-010
HS-5	297	267	33	16	7	1002-011
HS-6	335	310	36	19	10	1002-012
HS-8	373	355	41	19	16	1002-013