

VDI - E2 Boring Bar Holder - VDI 16

https://www.kfh-hermann.de/shop/product_info.php?products_id=467&XTCSid=n7eemf1jolajl8itk84fees403



Illustration



(https://www.kfh-hermann.de/shop/shop/images/product_images/original_images/bilder_B47-E2.jpg?XTCSid=n7eemf1jolajl8itk84fees403)

Drawing

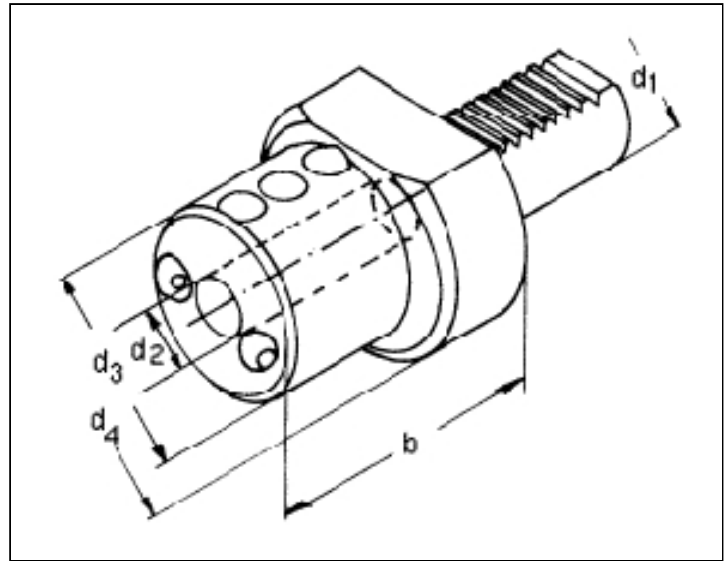

(https://www.kfh-hermann.de/shop/shop/images/product_images/original_images/skizzen_Z47-E2.jpg?XTCSid=n7eemf1jolajl8itk84fees403)

Technical information

Usage:	for clamping of cylindric shafts
Customs tariff code:	84 661 03 1

Variants

Product No.	d1	d2	b	B4	weight in kg	Stock 12.02, 08:14	Net-price
VDI E2 16x06x44	16	6	44	40	0,35	1	Please start an inquiry
VDI E2 16x08x44	16	8	44	40	0,35	2	Please start an inquiry
VDI E2 16x10x44	16	10	44	40	0,35	2	Please start an inquiry
VDI E2 16x12x44	16	12	44	40	0,4	8	Please start an inquiry
VDI E2 16x16x44	16	16	44	40	0,5	3	Please start an inquiry

Stock data from 2024-02-12 08:14:41

Kontakt

KARL HERMANN GmbH | Varnbülerstrasse 10 - 12 | D - 71229 Leonberg | | Tel.: +49 (0)7152 / 93992-0 | Fax: +49 (0)7152 / 93992-4 | E-Mail: verkauf@kfh-hermann.de | Internet: <http://www.kfh-hermann.de>

2024-02-13 12:30:00, https://www.kfh-hermann.de/shop/product_info.php?products_id=467&XTCSid=n7eemf1jolajl8itk84fees403