

VDI - E2 Boring Bar Holder - VDI 50

https://www.kfh-hermann.de/shop/product_info.php?products_id=471&XTCsid=n7eemf1jolajl8itk84fees403



Illustration



(https://www.kfh-hermann.de/shop/shop/images/product_images/original_images/bilder_B47-E2.jpg?XTCsid=n7eemf1jolajl8itk84fees403)

Drawing

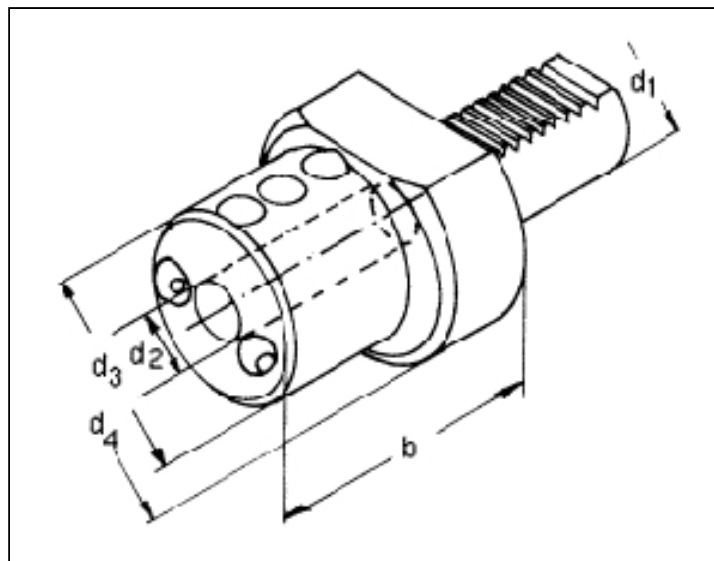

(https://www.kfh-hermann.de/shop/shop/images/product_images/original_images/skizzen_Z47-E2.jpg?XTCsid=n7eemf1jolajl8itk84fees403)

Technical information

Usage:	for clamping of cylindric shafts
Customs tariff code:	84 661 03 1

Variants

Product No.	d1	d2	b	d4	weight in kg	Stock 12.02, 08:14	Net-price
VDI E2 50x12x90	50	12	90		4,4	1	Please start an inquiry
VDI E2 50x16x90	50	16	90		4,3	2	Please start an inquiry
VDI E2 50x20x90	50	20	90		4,3	5	Please start an inquiry
VDI E2 50x25x90	50	25	90		4,1	1	Please start an inquiry
VDI E2 50x32x90	50	32	90		3,9	2	Please start an inquiry
VDI E2 50x40x90	50	40	90		5,2	11	Please start an inquiry
VDI E2 50x50x10	50	50	100		5,2	5	Please start an inquiry

Stock data from 2024-02-12 08:14:41

Kontakt

KARL HERMANN GmbH | Varnbülerstrasse 10 - 12 | D - 71229 Leonberg | | Tel.: +49 (0)7152 / 93992-0 | Fax: +49 (0)7152 / 93992-4 | E-Mail: verkauf@kfh-hermann.de | Internet: <http://www.kfh-hermann.de>

2024-02-13 12:31:00, https://www.kfh-hermann.de/shop/product_info.php?products_id=471&XTCsid=n7eemf1jolajl8itk84fees403

https://www.kfh-hermann.de/shop/print_product_info.php?products_id=471&XTCsid=n7eemf1jolajl8itk84fees403