

NEW

Heavy Duty Type, Rigid & Strong Design

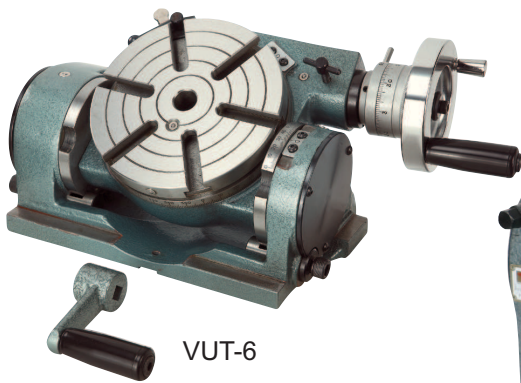

VUT-6

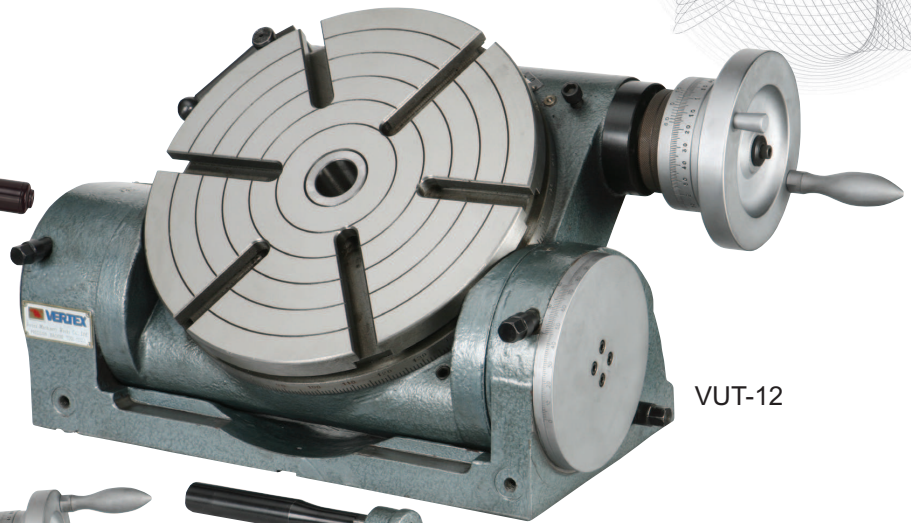

VUT-12

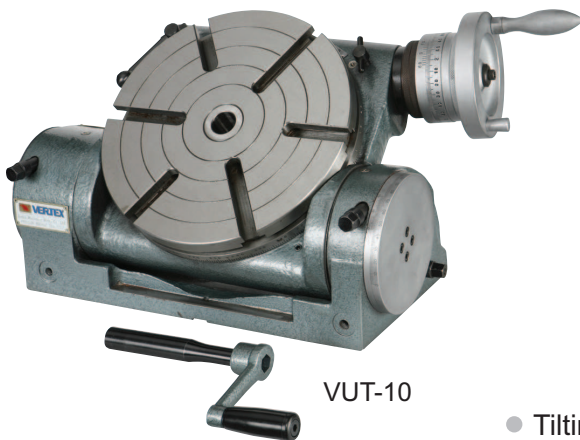

VUT-10

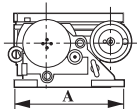
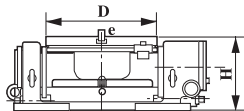
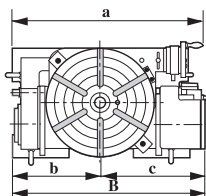
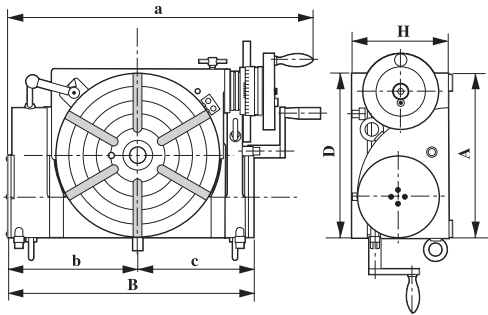

- Tilting by rigid & strong design, 2 supporter & rigid clamping system construction.
- Minimum set-up time.
- Tilting angle can adjusted by worm & worm gear system.
- Accurate and built for use in milling, boring and other machines.
- Indexing, facing and other operations can be done rapidly with extreme precision.
- Worm shafts are hardened and ground.
- Indexing can be done with optional dividing plates.
- DP-1 for VUT-6, DP-3 for VUT-10, VUT-12.
- Tailstock TS-1 for VUT-6, TS-3 for VUT-10, VUT-12.

MAIN SPECIFICATIONS		VUT-6	VUT-10, VUT-12
TILTING	Degree per one handle rotation	6°	1°
	vernier reading	1'	2'
TABLE	Degree per one handle rotation	4°	4°
	Scale of micro collar	1'	1'
	vernier reading	10"	10"
	Gear ratio	1:90	1:90

Specifications

ORDER NO.	TABLE DIAMETER & TABLE HEIGHT			MOUNTING SURFACE		OVER ALL SIZE			T-SOLT WIDTH	CENTER HOLE	CENTER HEIGHT (Tilted at 90°)	WEIGHT (kg)	CODE NO.
	D	H	h	A	B	a	b	c	e				
VUT-6	150	115	165	180	268	380	143	125	10	MT-2	90	23.5	1001-014
VUT-10	250	155	275	255	397	495	210	187	12	MT-3	150	75.5	1001-015
VUT-12	300	178	319	300	447	551	235	212	14	MT-4	169	108	1001-016