

TRM 16 Ø 18 ~ 23

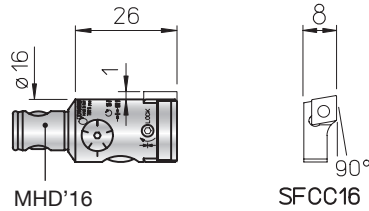

TRM 20 Ø 22 ~ 29

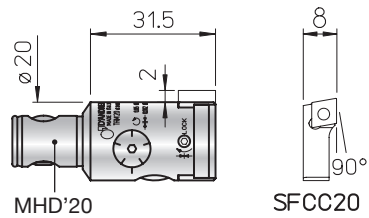

TRM 25 Ø 28 ~ 38

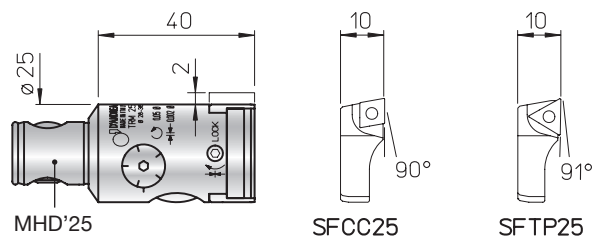

TRM 32 Ø 35.5 ~ 51.5

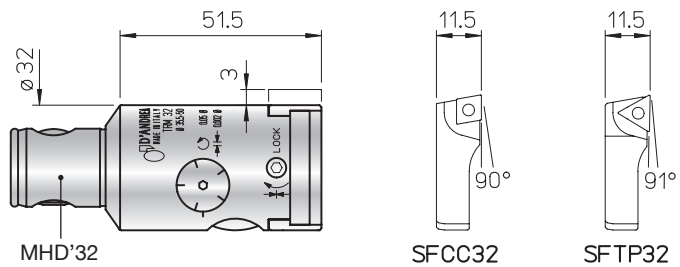

TRM 40 Ø 48 ~ 63

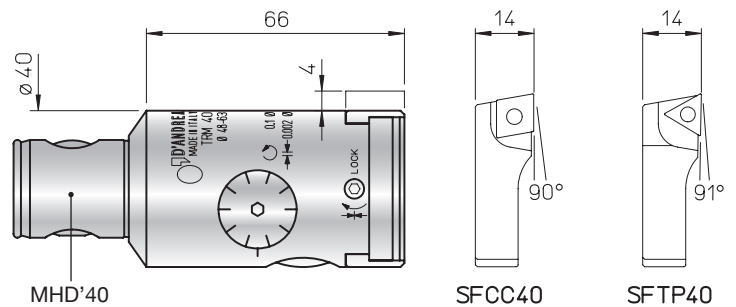

REF.	CODE	kg
TRM 16	455001600341	0.05
TRM 20	455002000401	0.1
TRM 25	455002500500	0.2
TRM 32	455003200630	0.35
TRM 40	455004000800	0.7

REF.	CODE		TORX T	kg
SFCC 16	470500516002	CCGT 0602..	TS 25 08	0.003
SFCC 20	470500520002	CCGT 0602..	TS 25 08	0.005
SFCC 25	470500525002	CCGT 0602..	TS 25 08	0.01
SFCC 32	470500532002	CCGT 0602..	TS 25 08	0.02
SFCC 40	470500540002	CCGT 09T3..	TS 4 15	0.04
SFTP 25	470500525001	TPGX 0902..	CS 250T 08	0.01
SFTP 32	470500532001	TPGX 0902..	CS 250T 08	0.02
SFTP 40	470500540001	TPGX 1103..	CS 300890T 08	0.04

• For back-facing machining see p.26

**TRM 50** Ø 2.5 ~ 108

**TRE 50 IP69K** Ø 2.5 ~ 110



**2 μm**

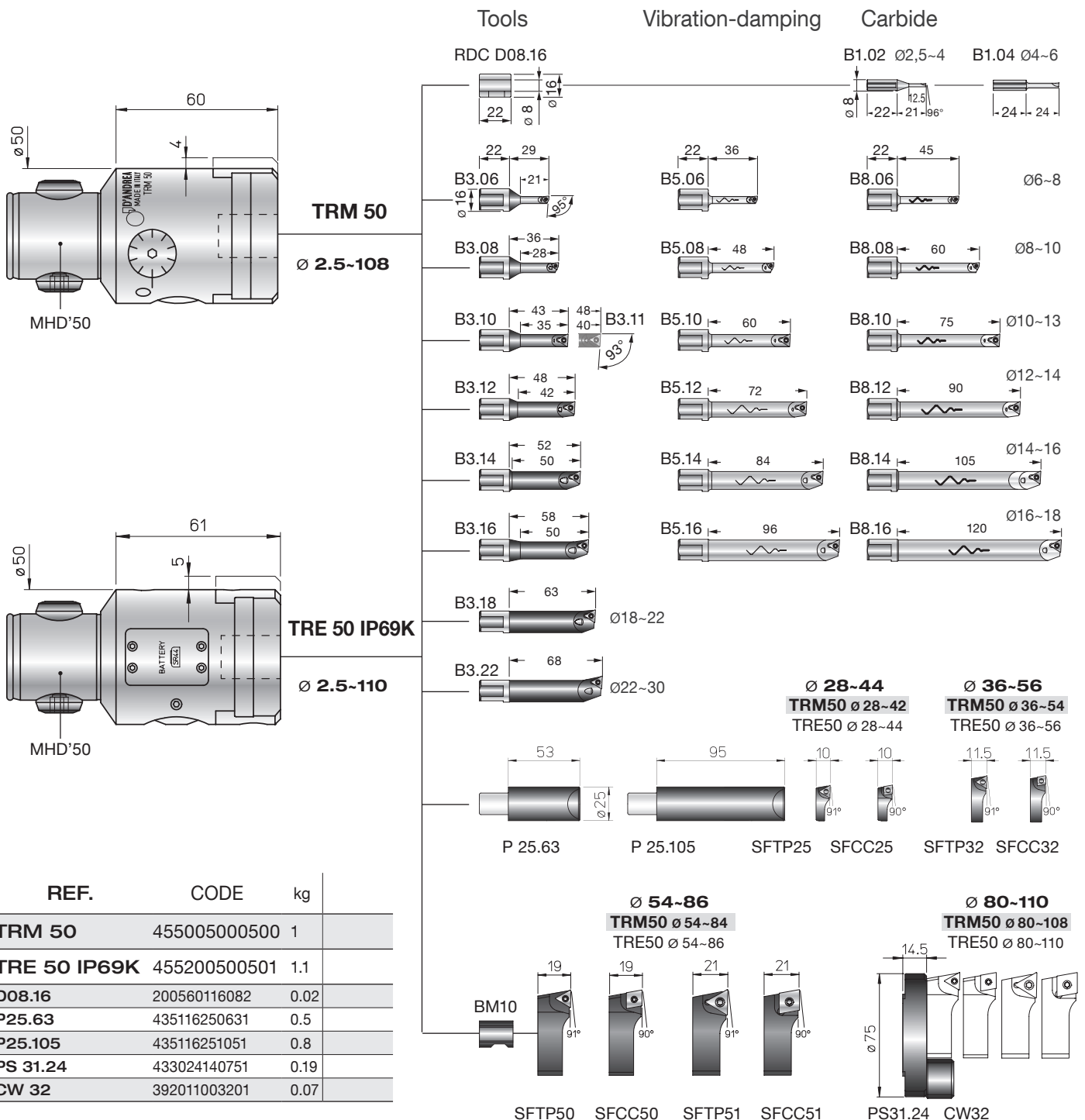

REF.	CODE	kg
TRM 50	455005000500	1
TRE 50 IP69K	455200500501	1.1
D08.16	200560116082	0.02
P25.63	435116250631	0.5
P25.105	435116251051	0.8
PS 31.24	433024140751	0.19
CW 32	392011003201	0.07

## TRM 50/63 - TRM 63/63

Ø 2.5 ~ 125

## TRM 50/80 - TRM 80/80

Ø 2.5 ~ 220



2 µm

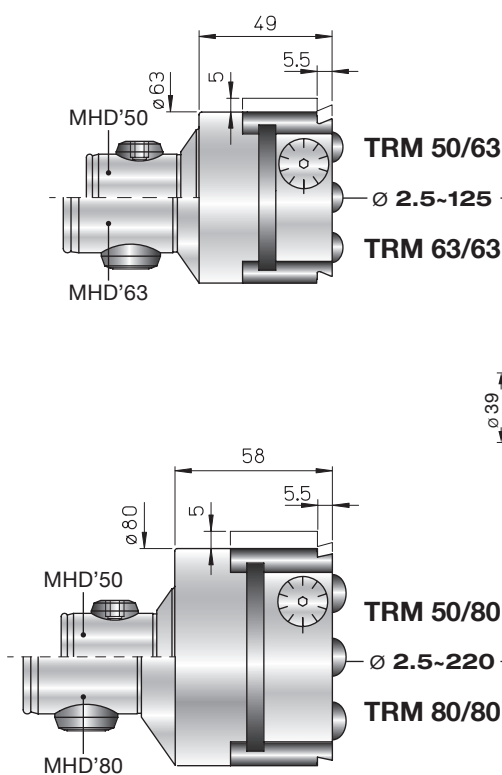

### Tools

### Vibration-damping

### Carbide

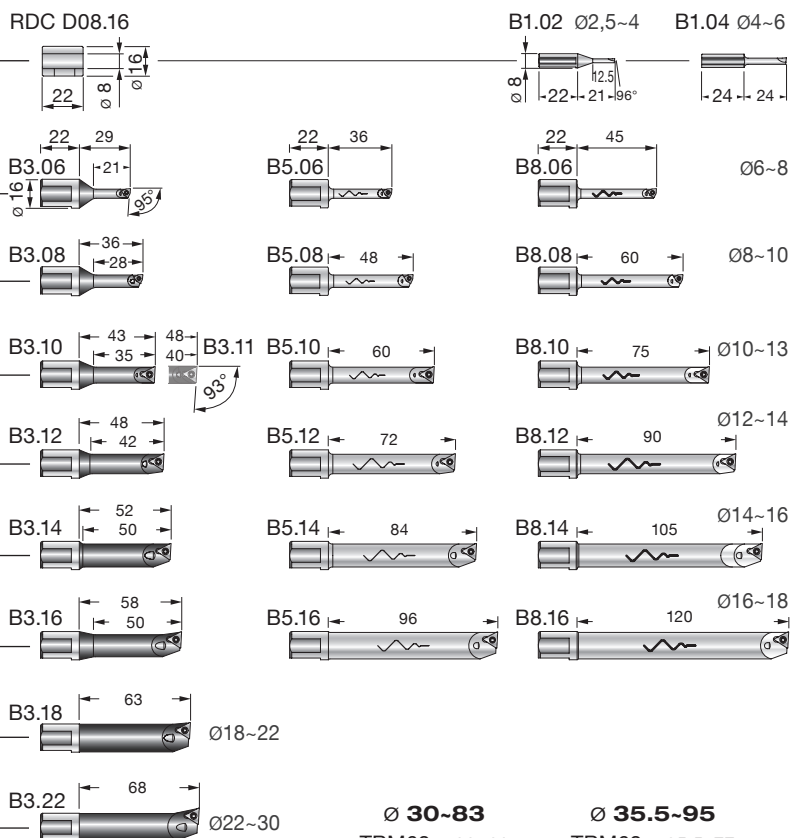

REF.	CODE	kg
TRM 50/63	455005000631	1.1
TRM 63/63	455006300631	1.5
TRM 50/80	455005000801	2
TRM 80/80	455008000801	2.5
D08.16	200560116082	0.02
P20.30	431030160300	0.2
P02.30	431030250400	0.3
P03.30	431030250700	0.4
P04.30	431030251150	0.7
PS 11.30	433030260750	0.4
PS 12.30	433030260950	0.5
PS 13.30	433030261400	0.7

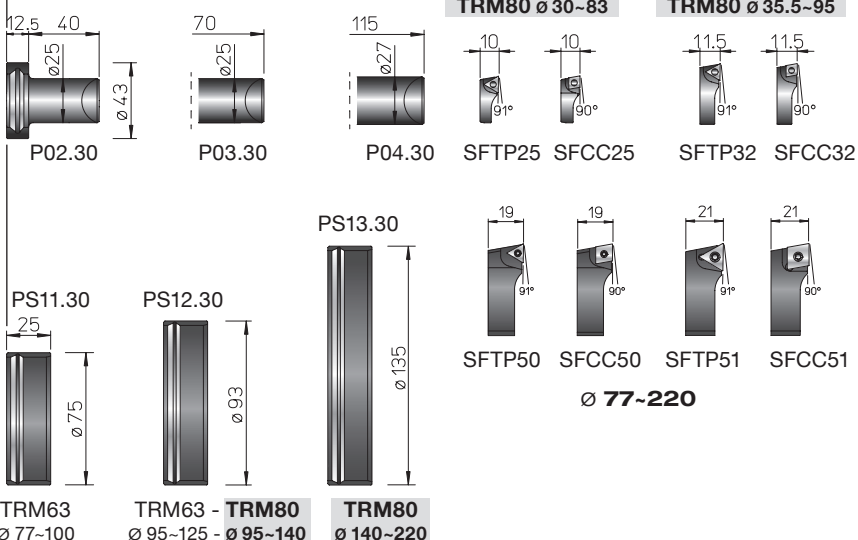

## TRM 80/125 $\varnothing 36 \sim 500$

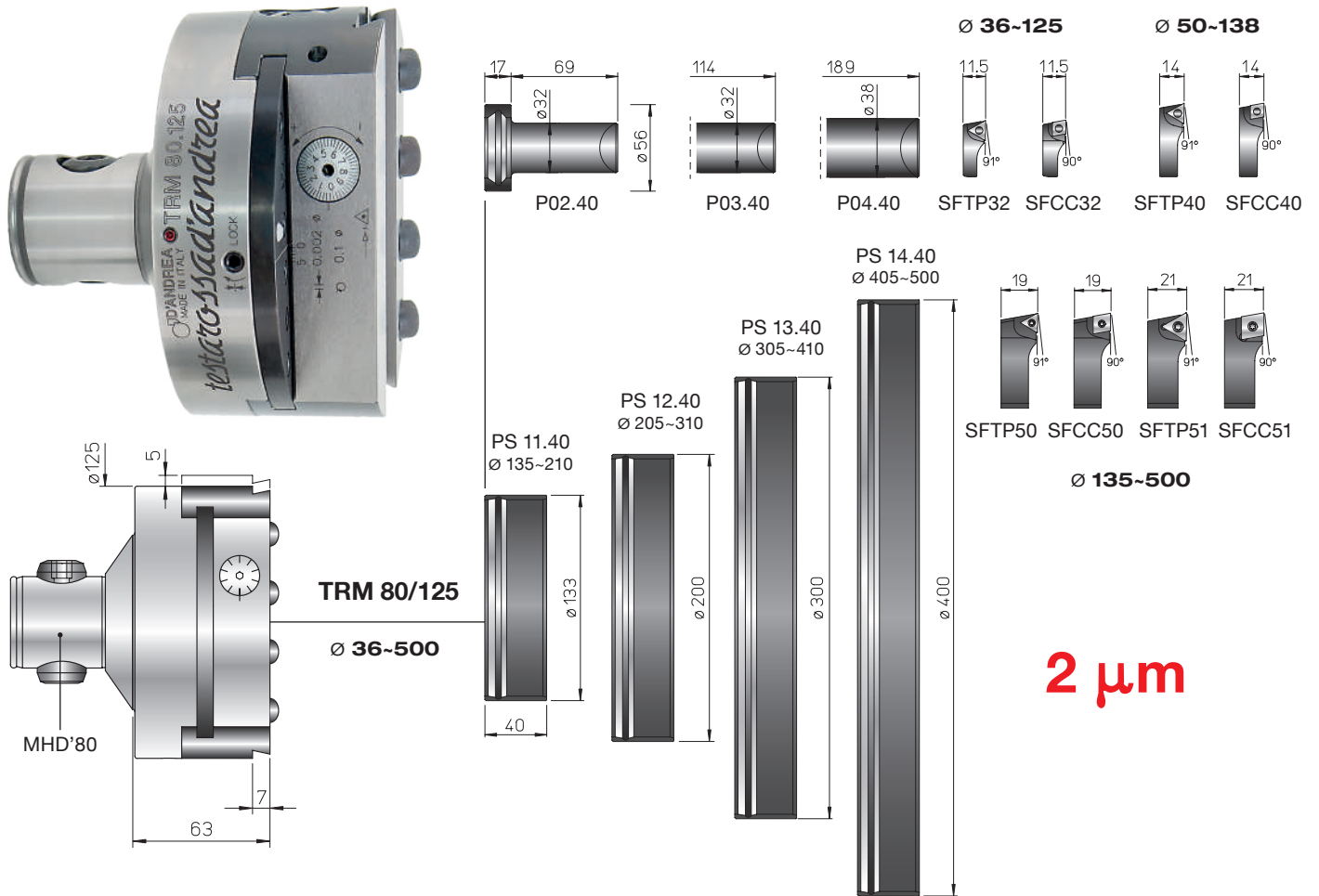

REF.	CODE	kg
TRM 80/125	455008001251	5.5
P02.40	431040320700	0.7
P03.40	431040321150	1
P04.40	431040321900	2

REF.	CODE	kg
PS 11.40	433040351500	1.5
PS 12.40	433040352300	2.4
PS 13.40	433040353300	3.5
PS 14.40	433040354000	4.6

## KIT K03 $\varnothing 36 \sim 410$

Working Range

TRM 80/125 EXCLUDED



- 1 PS11.40
- 1 PS12.40
- 1 PS13.40
- 1 PS13.40
- 1 P02.40
- 1 P03.40
- 1 P04.40
- 1 P04.40
- 1 SFTP32
- 1 SFTP40
- 1 SFTP50

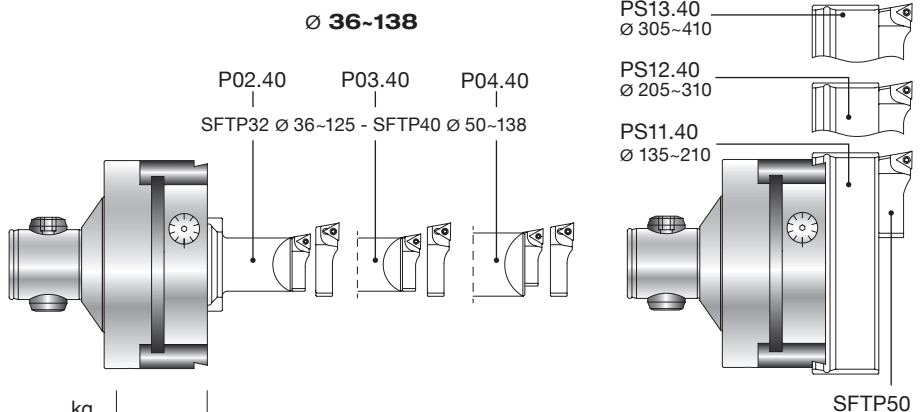

REF.	CODE	kg
KIT K03 TRM 80/125	655012500030	11.2

REF.	CODE	$\Delta$	$\square$	TORX T	kg
SFTP32	470500532001	TPGX 0902..	CS 250T	08	0.02
SFTP40	470500540001	TPGX 1103..	CS300890T	08	0.04
SFTP50	470500550001	TPGX 1103..	CS300890T	08	0.08
SFTP51	470500550003	TCMT 16T3..	TS 4	15	0.09

REF.	CODE	$\square$	$\square$	TORX T	kg
SFCC32	470500532002	CCGT 0602..	TS 25	08	0.02
SFCC40	470500540002	CCGT 09T3..	TS 4	15	0.04
SFCC50	470500550002	CCGT 09T3..	TS 4	15	0.08
SFCC51	470500550004	CCMT 1204..	TS 5	25	0.09

**PSC - PR**  
Extensions  
**PSC - RD**  
Reductions

- PSC50 - PR50
- PSC50 - RD50
- PSC63 - PR63
- PSC63 - RD63
- PSC80 - PR80

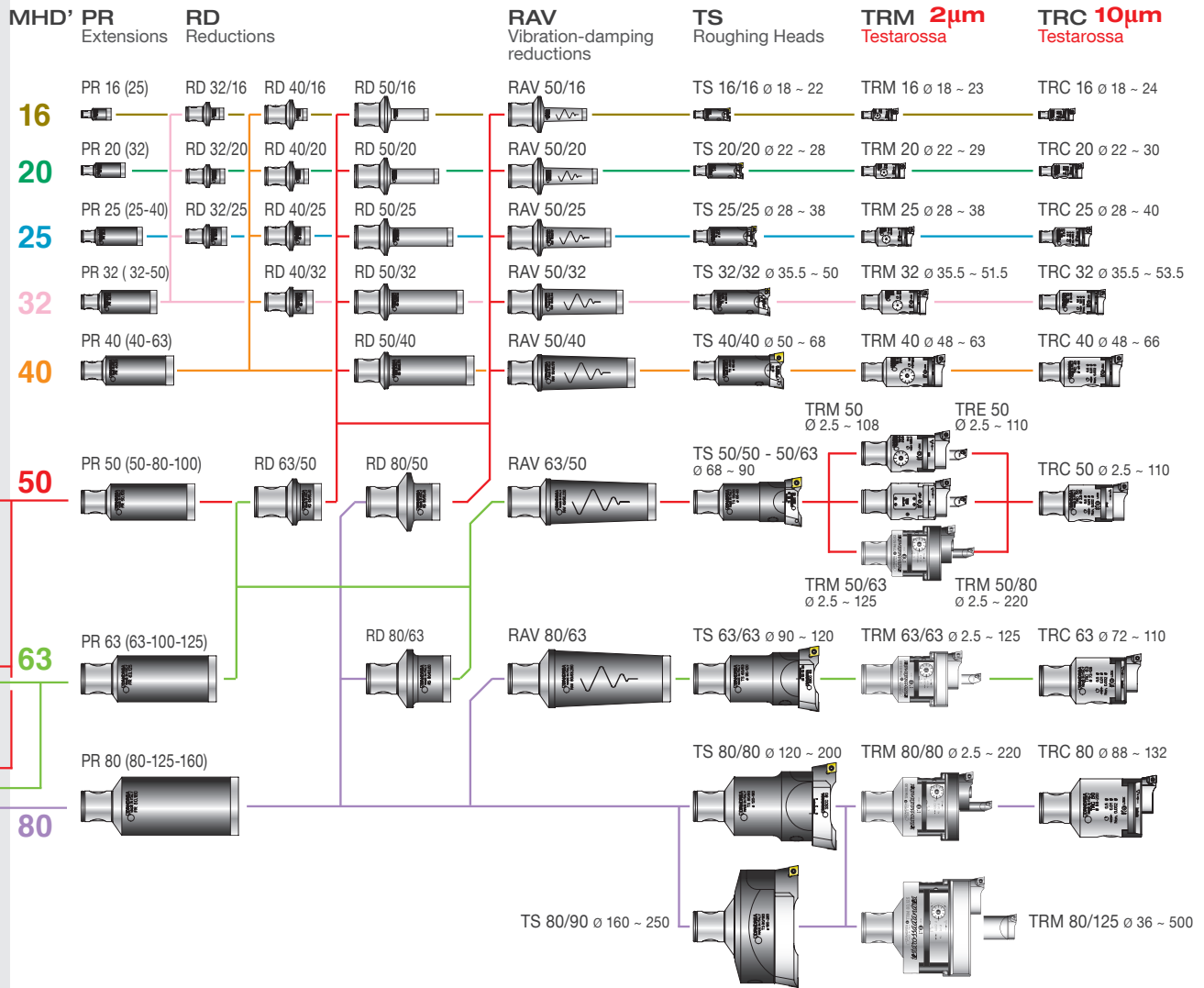
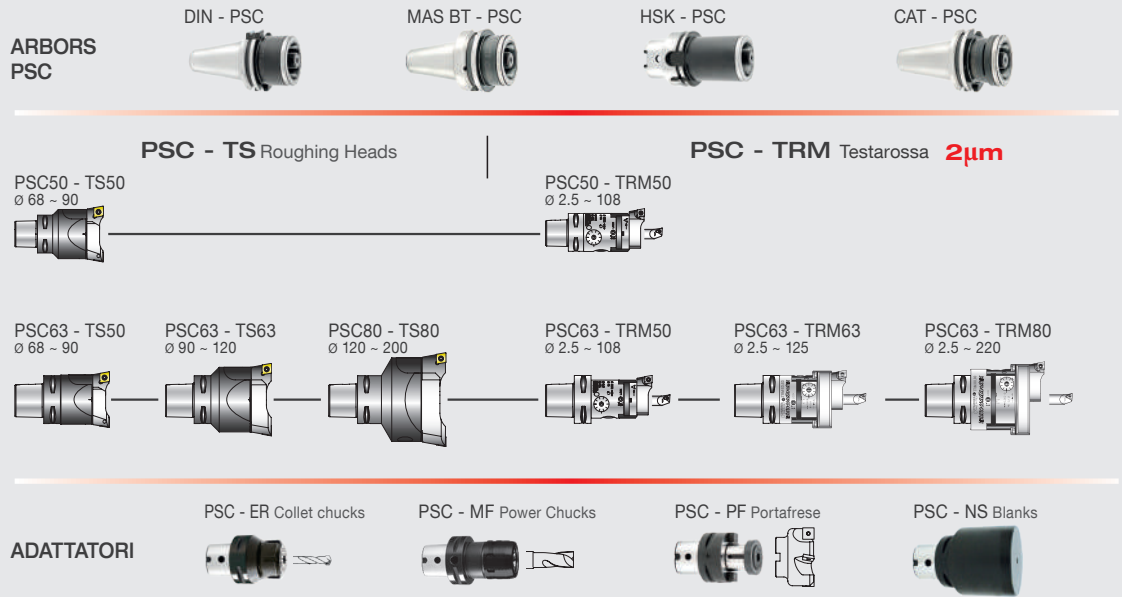

**CHUCKING TOOLS**

