

KIT K01 TRM 50/63 - 63/63

Ø 6 ~ 125



1 TRM 50/63 - 63/63

- 1 P20.30 1 B3.11
- 1 PS11.30 1 B3.16
- 1 P02.30 1 B3.22
- 1 P03.30 1 SFTP25
- 1 B3.06 1 SFTP32
- 1 B3.08 1 SFTP50

- 5 TPGX 090202L DC100
- 1 TPGX 110302L DC100
- 2 WCGT 020102L DC 10

REF.	CODE	kg	
KIT K01 TRM50/63	655005010632	3.9	
KIT K01 TRM63/63	655006310632	4.2	

KIT K01 TRM 50/80 - 80/80

Ø 6 ~ 220



1 TRM 50/80 - 80/80

- 1 P20.30 1 B3.08
- 1 PS12.30 1 B3.11
- 1 PS13.30 1 B3.16
- 1 P02.30 1 B3.22
- 1 P03.30 1 SFTP25
- 1 P04.30 1 SFTP32
- 1 B3.06 1 SFTP50

- 5 TPGX 090202L DC100
- 1 TPGX 110302L DC100
- 2 WCGT 020102L DC 10

REF.	CODE	kg	
KIT K01 TRM50/80	655005010802	6.2	
KIT K01 TRM80/80	655008010802	6.6	

KIT K01 TRM 50/63 - 63/63

Working Range

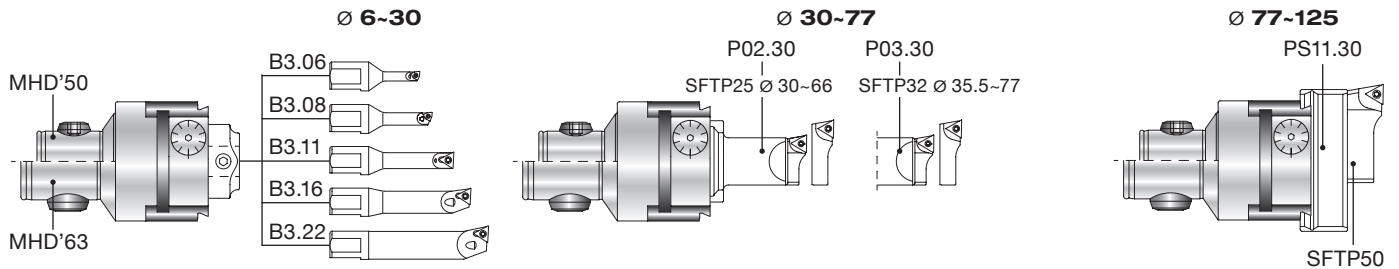

KIT K01 TRM 50/80 - 80/80

Working Range

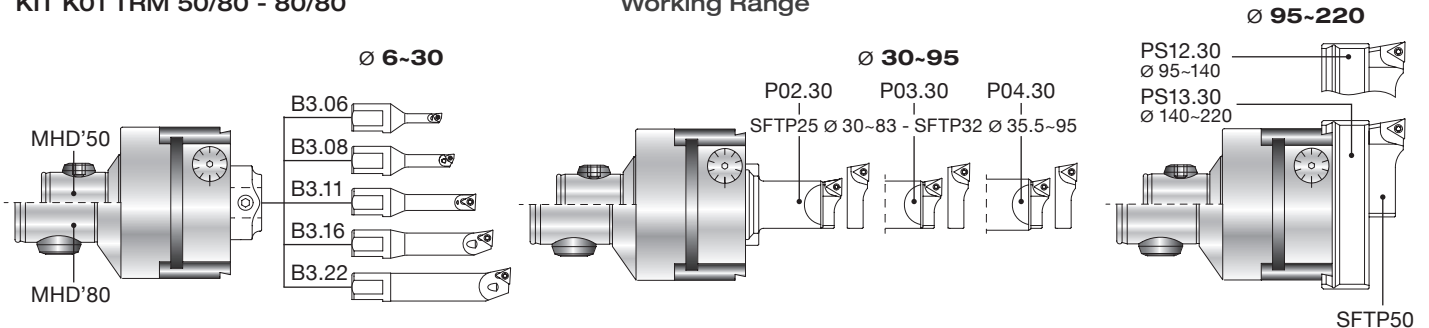

REF.	CODE		TORX T	kg
B1.02	572010502001			0.02
B1.04	572010504001			0.02
B3.06	572010506001	WCGT0201..	TS 21 06	0.035
B3.08	572010508001	WCGT0201..	TS 211 06	0.4
B3.10	572010510001	TPGX0902..	CS 250 T 08	0.05
B3.11	572010511001	TPGX0902..	CS 250 T 08	0.055
B3.12	572010512001	TPGX0902..	CS 250 T 08	0.06
B3.14	572010514001	TPGX0902..	CS 250 T 08	0.07
B3.16	572010516001	TPGX0902..	CS 250 T 08	0.07
B3.18	572010518001	TPGX0902..	CS 250 T 08	0.1
B3.22	572010522001	TPGX0902..	CS 250 T 08	0.1

REF.	CODE		TORX T	kg
B5.06	572010506105	WCGT0201..	TS 21 06	0.075
B5.08	572010508105	WCGT0201..	TS 211 06	0.09
B5.10	572010510105	TPGX0902..	CS 250 T 08	0.1
B5.12	572010512105	TPGX0902..	CS 250 T 08	0.1
B5.14	572010514105	TPGX0902..	CS 250 T 08	0.2
B5.16	572010516105	TPGX0902..	CS 250 T 08	0.3
B8.06	572010506108	WCGT0201..	TS 21 06	0.065
B8.08	572010508108	WCGT0201..	TS 211 06	0.08
B8.10	572010510108	TPGX0902..	CS 250 T 08	0.1
B8.12	572010512108	TPGX0902..	CS 250 T 08	0.2
B8.14	572010514108	TPGX0902..	CS 250 T 08	0.2
B8.16	572010516108	TPGX0902..	CS 250 T 08	0.3

REF.	CODE		TORX T	kg
SFTP25	470500525001	TPGX0902..	CS 250T 08	0.01
SFTP32	470500532001	TPGX0902..	CS 250T 08	0.02
SFTP50	470500550001	TPGX1103..	CS300890T 08	0.08
SFTP51	470500550003	TCMT16T3..	TS 4 15	0.09

REF.	CODE		TORX T	kg
SFCC25	470500525002	CCGT0602..	TS 25 08	0.01
SFCC32	470500532002	CCGT0602..	TS 25 08	0.02
SFCC50	470500550002	CCGT09T3..	TS 4 15	0.08
SFCC51	470500550004	CCMT1204..	TS 5 25	0.09

• For back-facing machining see p.26