

The new **BHT** boring system is characterized by the new **HT** coupling suitable for medium-heavy machining, characterized by strong torsional components with maximum concentricity.

BHT bars cover a working range from \varnothing 250 to \varnothing 750 mm, both in roughing and finishing.

The wide range of accessories includes adjustable ISO-CA roughing cartridges and a standard TRM 63 finishing micrometric head, suitable for boring, chamfering and back-facing operations.

The system in FINISHING configuration can be balanced by using counterweights.

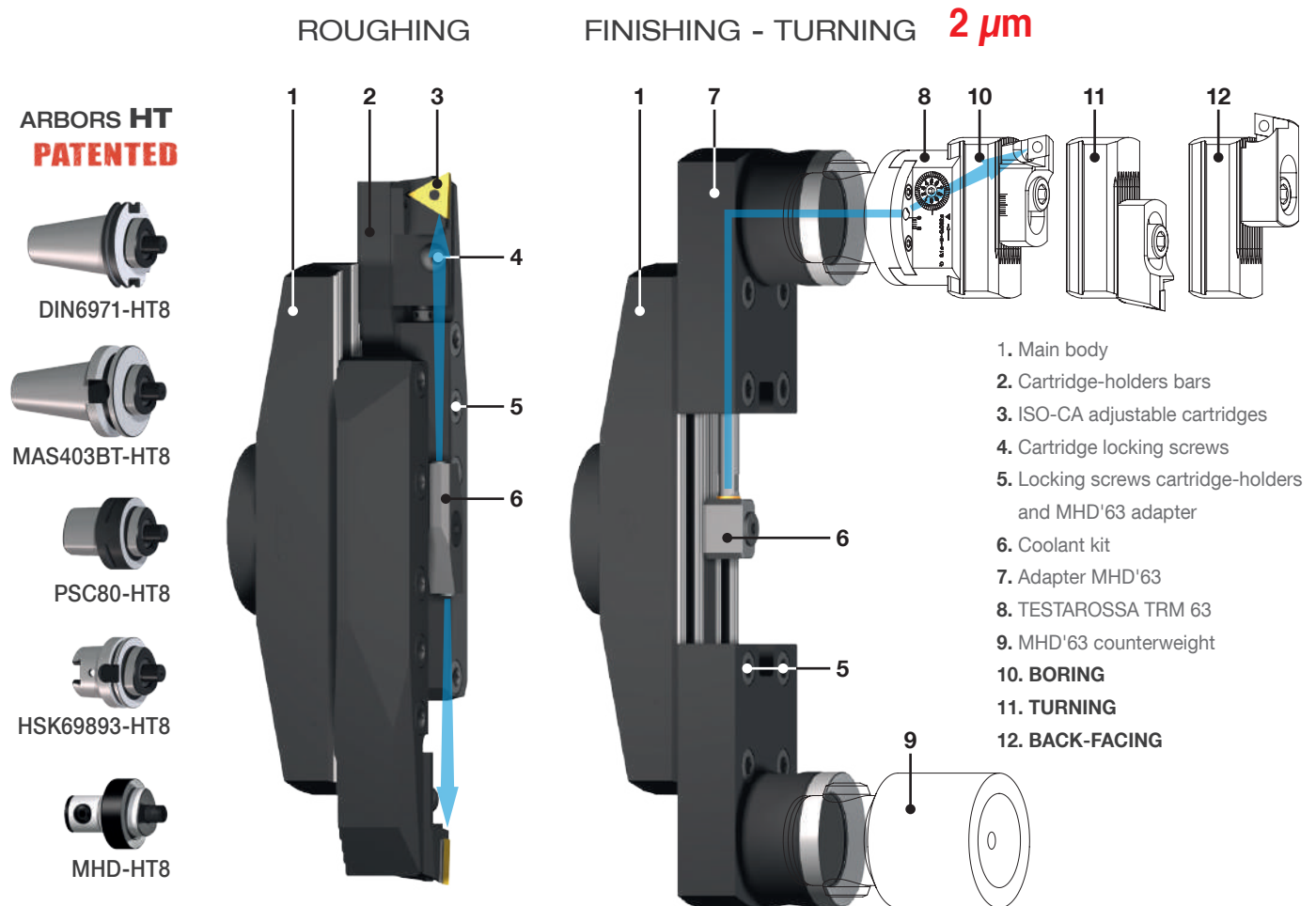

12. BACKWARD

For **ROUGHING** operations
use TS 63/63+SSQC 63 see page 26

For **FINISHING** operations
use TRM 63+PS..+SFQC 50 see page 26

REF.	CODE	\varnothing	A	kg
BHT 250	435508882460	250 ~ 500	246	4.2
BHT 500	435508882960	500 ~ 750	496	7.8

REF.	CODE	kg
DIN 69871-AD50 - HT8.36.5	41HT08025000	3.4
MAS403BT-AD50 - HT8.38.5	41HT08035000	3.7
PSC 80 - HT8.30	41HT08018000	2
HSK 100 - HT8.76.5	41HT08041000	4
MHD' 80 - HT8	655108000080	2

