

Cantoni<sup>®</sup> GROUP **FENES<sup>®</sup>** S.A.

[www.fenes.com.pl](http://www.fenes.com.pl)



narzędzia do  
**gwintowania**

tools for  
threading



# spis treści

## list of contents

### typ narzędzia

#### type of tool

DIN

str;  
page

gwintowniki maszynowe <b>do gwintu metrycznego zwykłego</b> machine taps <b>for metric coarse thread</b>	<b>M</b>	<b>371, 376</b>	<b>01</b>
gwintowniki maszynowe <b>do gwintu metrycznego drobnozwojnego</b> machine taps <b>for metric fine thread</b>	<b>MF</b>	<b>374</b>	<b>02</b>
gwintowniki maszynowe <b>do gwintu rurowego walcowego</b> machine taps <b>for whitworth pipe thread</b>	<b>G</b>	<b>5156</b>	<b>03</b>
gwintowniki ręczne <b>do gwintu metrycznego zwykłego</b> [komplet 3 szt.] hand taps <b>for metric coarse thread</b> [complete set]	<b>M</b>	<b>352</b>	<b>04</b>
gwintowniki ręczne <b>do gwintu metrycznego drobnozwojnego</b> [komplet 2 szt.] hand taps <b>for metric fine thread</b> [complete set]	<b>MF</b>	<b>2181</b>	<b>05</b>
gwintowniki ręczne <b>do gwintu rurowego walcowego</b> [komplet 2 szt.] hand taps <b>for whitworth pipe thread</b> [complete set]	<b>G</b>	<b>5157</b>	<b>06</b>
narzynki ogólnego przeznaczenia <b>do gwintu metrycznego zwykłego</b> general purpose screwing dies <b>for metric coarse thread</b>	<b>M</b>	<b>EN 22568</b>	<b>07</b>

### informacje techniczne

#### technical information

<b>gwintowniki; taps</b>	
dobór gwintownika; selection of the tap	<b>08</b>
materiały używane do produkcji gwintowników; materials used for tap's producing	<b>08</b>
rodzaje nakrojów i rowków wiórowych; type of chamfers and flutes	<b>08</b>
obróbka powierzchniowa - powłoki; surface machining - coating	<b>09</b>
klasy gwintowników a pola tolerancji gwintu wewnętrznego; tap's classes and inner thread's tolerance zone	<b>09</b>
dobór parametrów skrawania w zależności od obrabianego materiału; machining parameters depending on machined material	<b>10</b>
<b>narzynki; screwing dies</b>	
materiały używane do produkcji narzynek; materials used for screwing die's producing	<b>11</b>
dobór parametrów skrawania w zależności od obrabianego materiału; machining parameters depending on machined material	<b>11</b>
materiały obrabiane [załącznik 1]; machined materials [attachment 1]	<b>12</b>

# gwintowniki maszynowe do gwintu metrycznego zwykłego

## machine taps for metric coarse thread

gwint metryczny zwykły wg  
metric coarse thread acc. to

[ISO DIN-13]  
[ISO DIN-13]

# M

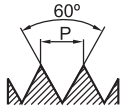

**DIN 371**

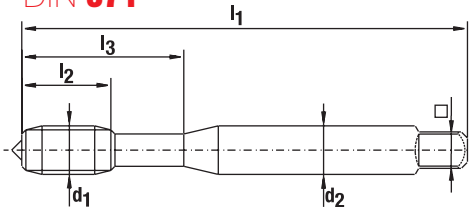

**DIN 376**

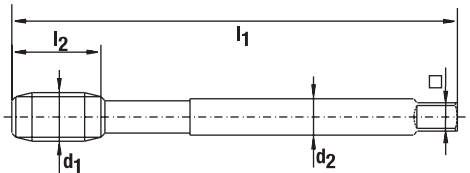

Zastosowanie; Application Rm [N/mm<sup>2</sup>]

Materiał; Material

Typ otworu; Type of hole

Nakrój; Chamfer

Tolerancja; Tolerance

Powłoka; Coating

DIN 371 Index

DIN 376 Index



≤ 800		≤ 1000		≤ 1200		1200 ≤ 1400	
HSS-E	HSS-E	HSS-E	HSS-E	HSS-E	HSS-E	HSS-E	HSS-E
B	C	B	C	B	C	B	C
ISO-2 6H	ISO-2 6H	ISO-2 6H	ISO-2 6H	ISO-2 6H	ISO-2 6H	ISO-2 6H	ISO-2 6H
OX	OX	TiN	TiN	TiN	TiN	TiCN	TiCN
0641-305-100...	0641-305-110...	0641-305-120...	0641-305-130...	0641-305-140...	0641-305-150...	0641-305-160...	0641-305-170...
0641-305-105...	0641-305-115...	0641-305-125...	0641-305-135...	0641-305-145...	0641-305-155...	0641-305-165...	0641-305-175...

**DIN 371**

d <sub>1</sub>
M 3
M 4
M 5
M 6
M 8
M 10

P [mm]	l <sub>1</sub>	l <sub>2</sub>		l <sub>3</sub>	d <sub>2</sub>	□		index
		B	C					
0,5	56	10	6	18	3,5	2,7	2,5	...030
0,7	63	12	8	21	4,5	3,4	3,3	...040
0,8	70	14	10	25	6	4,9	4,2	...050
1	80	16	12	30	6	4,9	5,0	...060
1,25	90	18	15	35	8	6,2	6,8	...080
1,5	100	20	18	39	10	8	8,5	...100

**DIN 376**

d <sub>1</sub>
M 12

P [mm]	l <sub>1</sub>	l <sub>2</sub>		d <sub>2</sub>	□		index
		B	C				
1,75	110	22	18	3,5	7	10,2	...120

\* Na specjalne zamówienie wykonujemy gwintowniki o wymiarach innych niż zawarte w tabeli; For the special order we make taps of other dimensions than contained in table.

Przykład zamówienia; Example of order

Gwintownik DIN 371-B M 4/1000 lub nr indexu 0641-305-120-040;  
Tap DIN 371-B M 4/1000 or index 0641-305-120-040

# gwintowniki maszynowe do gwintu metrycznego drobnozwojnego machine taps for metric fine thread

gwint metryczny drobnozwojny wg  
metric fine thread acc. to

[ISO DIN-13]  
[ISO DIN-13]

# MF

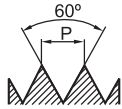

DIN 374

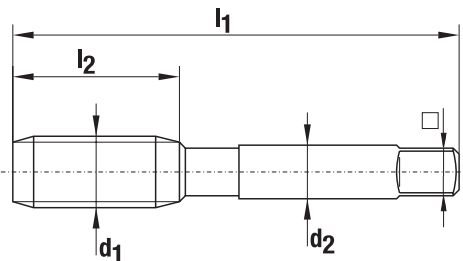

Zastosowanie; Application	Rm [N/mm <sup>2</sup> ]
Materiał; Material	
Typ otworu; Type of hole	
Nakrój; Chamfer	
Tolerancja; Tolerance	
Powłoka; Coating	
DIN 374	Index



≤ 800		≤ 1000		≤ 1200		1200 ≤ 1400	
HSS-E	HSS-E	HSS-E	HSS-E	HSS-E	HSS-E	HSS-E	HSS-E
B	C	B	C	B	C	B	C
ISO-2 6H	ISO-2 6H	ISO-2 6H	ISO-2 6H	ISO-2 6H	ISO-2 6H	ISO-2 6H	ISO-2 6H
OX	OX	TiN	TiN	TiN	TiN	TiCN	TiCN
0641-305-500...	0641-305-505...	0641-305-510...	0641-305-515...	0641-305-520...	0641-305-525...	0641-305-530...	0641-305-535...

DIN 374

d <sub>1</sub>
M 8 x 1
M 10 x 1,25
M 12 x 1,25
M 12 x 1,5

P [mm]	l <sub>1</sub>	l <sub>2</sub>	d <sub>2</sub>			index
1	90	15	6	4,9	7,0	...080
1,25	100	18	7	5,5	8,8	...100
1,25	100	18	9	7	10,8	...120
1,5	100	18	9	7	10,5	...121

\* Na specjalne zamówienie wykonujemy gwintowniki o wymiarach innych niż zawarte w tabeli; For the special order we make taps of other dimensions than contained in table.

### Przykład zamówienia; Example of order

Gwintownik DIN 374-B M 8 x 1/1000 lub nr indexu 0641-305-510-080;  
Tap DIN 374-B M 8 x 1/1000 or index 0641-305-510-080

# gwintowniki maszynowe do gwintu rurowego walcowego machine taps for whitworth pipe thread

gwint rurowy walcowy wg [ISO DIN-228]  
whitworth pipe thread acc. to [ISO DIN-228]

# G

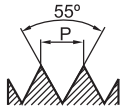

## DIN 5156

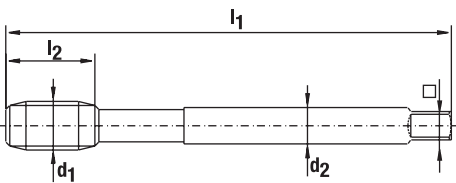

Zastosowanie; Application	Rm [N/mm <sup>2</sup> ]
Materiał; Material	
Typ otworu; Type of hole	
Nakrój; Chamfer	
Tolerancja; Tolerance	
Powłoka; Coating	
DIN 5156	Index

≤ 800		≤ 1200	
HSS-E	HSS-E	HSS-E	HSS-E
B	C	B	C
-	-	-	-
OX	OX	TiN	TiN
0641-310-105...	0641-310-110...	0641-310-115...	0641-310-120...

## DIN 5156

d <sub>1</sub>
G 1/8
G 1/4

P [Gg/1"]	l <sub>1</sub>	l <sub>2</sub>	d <sub>2</sub>			index
28	90	16	7	5,5	8,8	...005
19	100	18	11	9	11,8	...010

\* Na specjalne zamówienie wykonujemy gwintowniki o wymiarach innych niż zawarte w tabeli; For the special order we make taps of other dimensions than contained in table.

### Przykład zamówienia; Example of order

Gwintownik DIN 5156-B G 1/8/800 lub nr indexu 0641-310-105-005;  
Tap DIN 5156-B G 1/8/800 or index 0641-310-105-005

gwintowniki ręczne **do gwintu metrycznego zwykłego** [komplet 3 szt.]  
 hand taps **for metric coarse thread** [complete set]

gwint metryczny zwykły wg  
 metric coarse thread acc. to

[ISO DIN-13]  
 [ISO DIN-13]

**M**

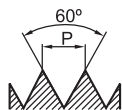

**DIN 352**

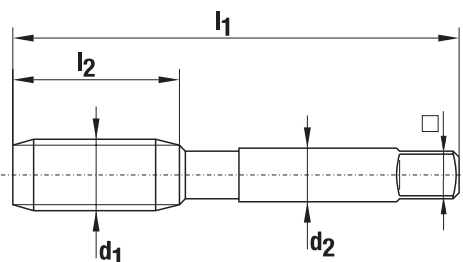

Zastosowanie; Application Rm [N/mm<sup>2</sup>]

Materiał; Material

Typ otworu; Type of hole

Nakrój; Chamfer

Tolerancja; Tolerance

Powłoka; Coating

DIN **352**

Index



≤ 800

HSS



A

ISO-2 6H

-

0641-300-100...

**DIN 352**

d <sub>1</sub>
M 3
M 4
M 5
M 6
M 8
M 10
M 12

P [mm]	l <sub>1</sub>	l <sub>2</sub>	d <sub>2</sub>	□		index
0,5	40	11	3,5	2,7	2,5	...030
0,7	45	13	4,5	3,4	3,3	...040
0,8	50	16	6	4,9	4,2	...050
1	56	18	6	4,9	5,0	...060
1,25	63	18	6	4,9	6,8	...080
1,5	70	23	7	5,5	8,5	...100
1,75	75	28	9	7	10,2	...120

\* Na specjalne zamówienie wykonujemy gwintowniki o wymiarach innych niż zawarte w tabeli; For the special order we make taps of other dimensions than contained in table.

**Przykład zamówienia; Example of order**

Gwintownik DIN 352 M 4 lub nr indexu 0641-300-100-040;  
 Tap DIN 352 M 4 or index 0641-300-100-040

gwintowniki ręczne **do gwintu metrycznego drobnozwojnego** [komplet 2 szt.]  
 hand taps **for metric fine thread** [complete set]

gwint metryczny drobnozwojny wg **[ISO DIN-13]**  
 metric fine thread acc. to **[ISO DIN-13]**

**MF**

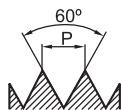

**DIN 2181**

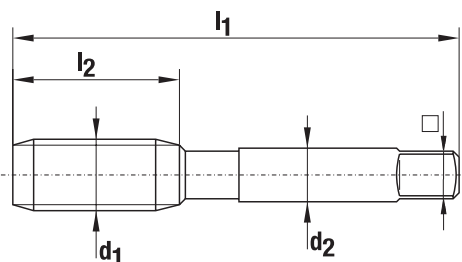

Zastosowanie; Application Rm [N/mm<sup>2</sup>]

Materiał; Material

Typ otworu; Type of hole

Nakrój; Chamfer

Tolerancja; Tolerance

Powłoka; Coating

**DIN 2181**

Index



≤ 800

HSS



A

ISO-2 6H

-

0641-300-105...

**DIN 2181**

d <sub>1</sub>
M 8 x 1
M 10 x 1,25
M 12 x 1,25
M 12 x 1,5

P [mm]	l <sub>1</sub>	l <sub>2</sub>	d <sub>2</sub>	□		index
1	63	18	6	4,9	7,0	...080
1,25	70	18	7	5,5	8,8	...100
1,25	70	20	9	7	10,8	...120
1,5	70	20	9	7	10,5	...121

\* Na specjalne zamówienie wykonujemy gwintowniki o wymiarach innych niż zawarte w tabeli; For the special order we make taps of other dimensions than contained in table.

**Przykład zamówienia; Example of order**

Gwintownik DIN 2181 M 8 x 1 lub nr indexu 0641-300-105-080;  
 Tap DIN 2181 M 8 x 1 or index 0641-300-105-080

# gwintowniki ręczne **do gwintu rurowego walcowego** [komplet 2 szt.] hand taps **for whitworth pipe thread** [complete set]

gwint rurowy walcowy wg **[ISO DIN-228]**  
whitworth pipe thread acc. to **[ISO DIN-228]**

# G

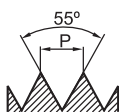

**DIN 5157**

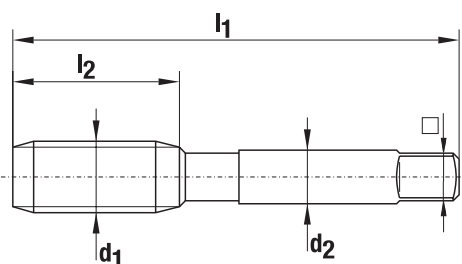

Zastosowanie; Application  $R_m$  [N/mm<sup>2</sup>]

Materiał; Material

Typ otworu; Type of hole

Nakrój; Chamfer

Tolerancja; Tolerance

Powłoka; Coating

**DIN 5157**

Index



$\leq 800$

HSS



A

-

-

0641-310-100...

**DIN 5157**

$d_1$
G 1/8
G 1/4

P [Gg/1"]	$l_1$	$l_2$	$d_2$	□		index
28	63	18	7	5,5	8,8	...005
19	70	20	11	9	11,8	...010

\* Na specjalne zamówienie wykonujemy gwintowniki o wymiarach innych niż zawarte w tabeli; For the special order we make taps of other dimensions than contained in table.

## Przykład zamówienia; Example of order

Gwintownik DIN 5157 G 1/8 lub nr indexu 0641-310-100-005;  
Tap DIN 5157 G 1/8 or index 0641-310-100-005



narzynki ogólnego przeznaczenia **do gwintu metrycznego zwykłego**  
 general purpose screwing dies **for metric coarse thread**

gwint metryczny zwykły wg  
 metric coarse thread acc. to

[ISO DIN-13]  
 [ISO DIN-13]

**M**

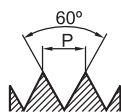

**DIN EN 22568**

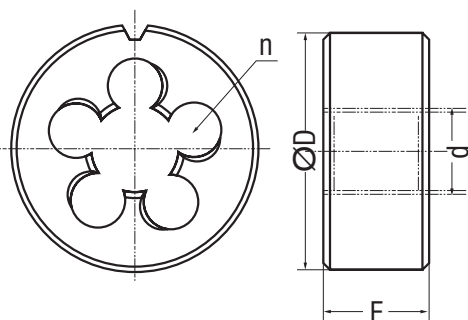

Materiał; Material

Nakrój; Chamfer

Tolerancja; Tolerance

DIN **EN 22568**

Index

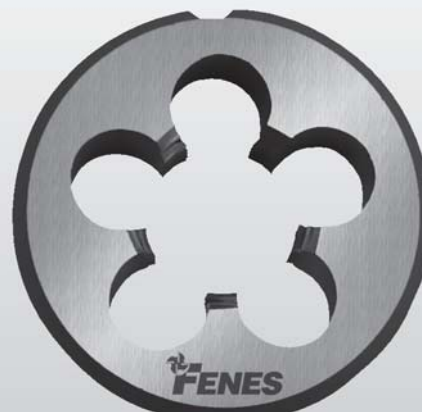

HSS

1,75 P

6 g

0641-340-100...

**DIN EN 22568**

d <sub>1</sub>
M 3
M 4
M 5
M 6
M 8
M 10
M 12
M 16
M 18
M 20
M 24

P [mm]	øD x E [mm]	ød [mm]	H	n	index
0,5	20 x 5	2,95		3	...030
0,7	20 x 5	3,91		3	...040
0,8	20 x 7	4,90		4	...050
1	20 x 7	5,88		4	...060
1,25	25 x 9	7,87		4	...080
1,5	30 x 11	9,85		4	...100
1,75	38 x 14	11,83		4	...120
2	45 x 18	15,82		5	...160
2,5	45 x 18	17,79		5	...180
2,5	45 x 18	19,79		5	...200
3	55 x 22	23,79		5	...240

**Przykład zamówienia; Example of order**

Narzynka M 4 lub nr indexu 0641-340-100-040;  
 Screwing die M 4 or index 0641-340-100-040

## GWINTOWNIKI; TAPS

**Dobór gwintownika dla określonej obróbki przebiega w czterech etapach zależnych od następujących elementów;**  
**Selection of the tap is running in 4 stages depended on below:**

- Rodzaju gwintu; Type of thread
- Rodzaju obróbki (ręczna czy maszynowa); Type of machining (hand or machine)
- Materiału obrabianego; Mechined material
- Rodzaju otworu gwintowanego (przelotowy lub nieprzelotowy); Type of threaded hole (through or blind)

**Należy również dobrać średnicę otworu (wierćła), w którym nacięty będzie gwint.**  
**It should selected hole diameter (drill), where will be thread cut.**

### Materiały używane do produkcji gwintowników; Materials used for tap's producing

Symbol	Gatunek stali wg PN-77/H-85023 i PN-86/H-85022; Grade of steel acc. to PN-77/H-85023 and PN-86/H-85022	Oznaczenie wg DIN; Designation acc. to DIN	Przeznaczenie; Destination
<b>HSS</b>	Stal szybko tnąca; High speed steel SW7M	1.3343 S-6-5-2	Gwintowniki ręczne; Hand taps
<b>HSS-E</b>	Stal szybko tnąca; High speed steel SK5M	1.3243 S-6-5-2-5	Gwintowniki maszynowe; Machine taps

### Rodzaje nakrojów i rowków wiórowych; Type of chamfers and flutes

#### Nakroje gwintowników maszynowych; Chamfer of machine taps

Rodzaj nakroju; Type of chamfer -symbol	Długość nakroju wyrażona w ilości zwojów gwintu; Chamfer length presented In the quantity of the thread coils	Kąt nakroju; Chamfer angle	Rodzaj rowków wiórowych; Type of flutes	Zastosowanie; Application
A, B	(3,5 ÷ 5,5)P	8°	Proste (A), proste ze skośną powierzchnią natarcia (B); Straight (A), straight with spiral point (B)	Różnej długości otwory przelotowe w materiałach dających wióry średnie i długie; Different length through holes in materials forming medium and long chips
C	(2 ÷ 3)P	15°	Śrubowe; Spiral	Otwory nieprzelotowe, otwory przelotowe w materiałach dających wióry krótkie; Blind holes, through holes in materials forming short chips

#### W wykonaniu „FENES” S.A przyjęto:; In the standard of „FENES” S.A. are:

- Dla otworów przelotowych gwintowniki maszynowe posiadają rowki wiórowe proste ze skośną powierzchnią natarcia (nakrój B). W tym przypadku wióry są wypychane w kierunku gwintowania (do przodu) i przy wycofywaniu gwintownika nie powodują jego zakleszczania.;  
For through hole machine taps has got straight flutes with spiral points (type B). In this case chips are push forward towards threading and during return tap doesn't make its jam.
- Dla otworów nieprzelotowych gwintowniki maszynowe posiadają rowki skrętne, które podczas gwintowania „wyciągają” wióry z otworu (nakrój C). Jedynie gwintowniki ręczne mają rowki wiórowe proste (nakrój A).;  
For blind hole machine taps has got spiral flutes, which during threading push back chips from the hole (type C). Only hand taps has got straight flutes (type A).

**Obróbka powierzchniowa — powłoki; Surface machining — coating**

**Gwintowniki powlekane lub oksydowane; Coated or steam tempered taps**

Symbol	Nazwa; Name	Kolor; Colour	Twardość; Hardness HV 0,05	Zastosowanie; Application
OX	Oksydowany; steam tempered	Czarny; black	-	Uniwersalne; universal
TiN	Azotek tytanu; Titanium Nitride	Złoty; gold	2300	Uniwersalne; universal
TiCN	Węgloazotek tytanu Titanium Carbo-Nitride	Szarofioletowy; violet-grey	3000	Trudnoobrabialne, twarde stале; difficult workable, hard steels

**Klasy gwintowników a pola tolerancji gwintu wewnętrznego;  
Tap's classes and inner thread's tolerance zone**

Oferowane w naszym katalogu gwintowniki wykonywane są w klasie podstawowej przeznaczonej do najpowszechniej stosowanych tolerancji gwintu wewnętrznego, właściwych konkretnemu rodzajowi gwintu: dla gwintu metrycznego 6H, dla gwintu rurowego walcowego wg DIN ISO 228.

Klasy gwintowników (tzn. pola tolerancji części roboczej) do gwintu metrycznego są zunifikowane normami międzynarodowymi i krajowymi. Określona klasa gwintownika pozwala uzyskać gwinty o dwóch lub trzech polach tolerancji (patrz rysunek i tabela poniżej).

Taps offered in our catalogue are produced in the Basic class destined for the most common use of inner thread: for metric thread – 6H, for Whitworth pipe thread acc. to DIN ISO 228.

Taps classes (i.e. working part tolerance zones) for metric thread are unified by international and domestic standards. The determined tap class allows to obtain the threads of two or three tolerance zones (see picture and table below).

Gwint nakrętki Położenie tolerancji H; Internal thread Tolerance H limits	Klasa gwintownika; Tap tolerance limits	Gwint nakrętki Położenie tolerancji G; Internal thread Tolerance G limits
--	--	--

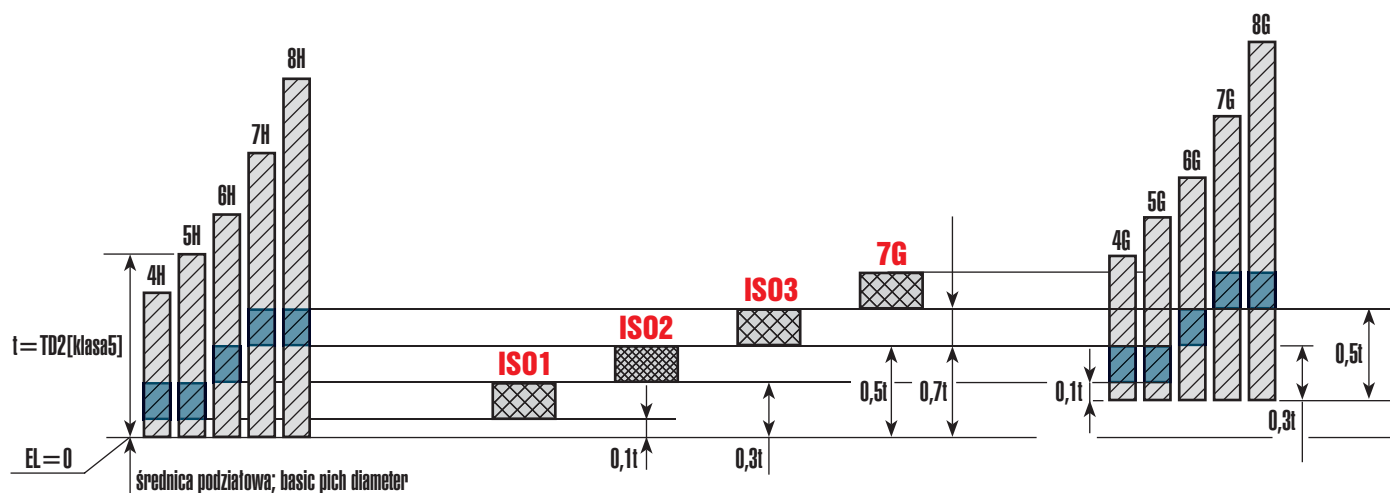

Symbol klasy wg normy; Tolerance class acc. to standard			Pole tolerancji gwintu wewnętrznego; Tolerance range of the internal thread			
PN-72 M-57800	PN-EN 22857 : 1999	DIN 802				
2A	ISO-2	6H	4G	5G	6H	

**Dobór parametrów skrawania w zależności od obrabianej grupy materiałowej;**  
**Machining parameters selection depending on material groups**

**GWINTOWNIKI MASZYNOWE; MACHINE TAPS**

1		2		1		2		1		2		Prędkość skrawania; Cutting speed $V_c$ [m/min]
Otwór przelotowy; Through hole		Otwór nieprzelotowy; Głębokość gwintu od $3 \times d_1$ ; Blind hole Depth of thread from $3 \times d_1$		B		C		B		C		
Typ otworu; Type of hole		Typ otworu; Type of hole		Nakrój; Chamfer		Nakrój; Chamfer		Nakrój; Chamfer		Nakrój; Chamfer		
1	Stale niestopowe; Unalloyed steels	$R_m \leq 800$ N/mm <sup>2</sup>		●	●	●	●	●	●			
2	Stale niestopowe i stopowe; Unalloyed and alloyed steels	$R_m \leq 1000$ N/mm <sup>2</sup>		○	○	●	●	●	●			$10 \div 20^* [1]$ $20 \div 50$
3	Stale niestopowe i stopowe; Unalloyed and alloyed steels	$R_m \leq 1200$ N/mm <sup>2</sup>						●	●	●	●	$5 \div 20 [1]$
4	Stale niestopowe i stopowe; Unalloyed and alloyed steels	$R_m \leq 1400$ N/mm <sup>2</sup>								●	●	$3 \div 10 [1]$
5	Stale nierdzewne i kwasoodporne; Stainless and acid resistand steels	[V2A]						●	●			$2 \div 5 [1]$
6	Stale nierdzewne i kwasoodporne z podwyższoną zawartością chromu i niklu; Stainless and acid resistand steels with higher content of chrom and nikiel	[V4A]						○	○			$10 \div 20 [1]$
7	Stale nierdzewne i kwasoodporne; Stainless and acid resistand steels	[V2A i V4A]						○	○			$10 \div 20 [1]$
8	Stale szybko tnące; High speed steels							●	●			$5 \div 20 [1]$
9	Żeliwo szare; Grey cast iron	[GG]						○	○			$10 \div 20 [2]$
10	Żeliwo sferoidalne, żeliwo ciągliwe; Spheroidal cast iron, malleable cast iron	[GGG, GT]						○	○			$20 \div 50 [2]$
11	Żeliwo wermikularne; Wermikular cast iron	[GGV, GJV, CGI]						○	○			$20 \div 50 [2]$
12	Aluminium, miedź, stopy miedzi; Aluminium, copper, copper alloys							○	○			$30 \div 50 [1]$
13	Stopy aluminium, stopy miedzi; Aluminium alloys, copper alloys							○	○			$30 \div 50 [1]$
14	Tworzywa termoplastyczne; Thermoplastics			○	○			○	○	○	○	$20 \div 30 [3]$

● Zastosowanie rekomendowane; Recommended application, ○ Zastosowanie warunkowe; Conditional application

[1] olej/emulsja; oil/emulsion, [2] emulsja lub bez chłodzenia; emulsion or without cooling, [3] bez chłodzenia lub powietrze; without cooling or air

\* dla gwintowników oksydacyjnych  $V_c = 10-20$  m/min, dla pozostałych  $V_c = 20-50$  m/min; for steam tempered taps  $V_c = 10-20$  m/min, for others  $V_c = 20-50$  m/min

Załącznik 1 (str. 12) przedstawia szczegółową tabelę materiałów obrabianych.;  
Attachment 1 (page 12) show particular table of machined materials

Przy gwintowaniu maszynowym zakres prędkości skrawania podany jest w katalogu w tabeli z materiałem i stąd można obliczyć obroty gwintownika;;  
During machined threading range of cutting speed is available in catalogue in material table, so you can calculate tap's Rpm (rotate per minute):

$$n = \frac{V_c \cdot 1000}{\pi \cdot d}$$

$V_c$  [m/min] - szybkość skrawania; cutting speed  
 $d$  [mm] - średnica gwintu (nominalna); thread diameter (nominal)  
 $\pi=3,14$

Należy pamiętać, że z obliczonego zakresu obrotów trzeba dobrać obroty optymalne (ustalone doświadczalnie) zależne m.in. od sztywności obrabiarki, sztywności przedmiotu gwintowanego i mocowania, stopnia stępienia gwintownika, rodzaju chłodzenia, itp.; Remember, that it should choose optimal Rpm (established experimentally) depending on for example rigid machine, rigid threaded element and clamping, grade of wear taps, type of cooling, etc.

#### GWINTOWNIKI RĘCZNE; HAND TAPS

W gwintownikach ręcznych szybkość skrawania jest zmienna i wymuszona przez osobę gwintującą. Należy pamiętać o okresowym wycofaniu gwintownika celem złamania i cofnięcia wiórów; In hand taps cutting speed is not constant and depends on threading man. Remember about periodic return tap in order to brake and back chips.

## NARZYNKI; SCREWING DIES

### Materiały używane do produkcji narzynek; Materials used for screwing die's producing

Symbol	Gatunek stali wg PN-77/H-85023 i PN-86/H-85022; Grade of steel acc. to PN-77/H-85023 and PN-86/H-85022	Oznaczenie wg DIN; Designation acc. to DIN	Przeznaczenie; Destination
<b>HSS</b>	Stal szybko tnąca; High speed steel SW7M	1.3343 S-6-5-2	Narzynki maszynowe ogólnego przeznaczenia, General purpose screwing dies

### Dobór parametrów skrawania w zależności od rodzaju obrabianego materiału; Machining parameters selection depending on machined material

Rodzaj materiału; Type of material	Przedstawiciele wg DIN; Representative acc. to DIN		Prędkość skrawania; Cutting speed $V_c$ [m/min]
	Oznaczenie; Designation	DIN Nr; No	
Stale niestopowe; Unalloyed steels $R_m \leq 800$ N/mm <sup>2</sup>	St37-3	1.0116	6 ÷ 14
	St52-3	1.0570	
	St60-2	1.0060	
	StE 255 (S255N)	1.0461	
	StE 460 (P460N)	1.8905	
	StE 500 (S500N)	1.8907	
	C10	1.0301	
	C22	1.0402	
	C35	1.0501	
	C40	1.0511	
	GS-38 (GE200)	1.0420	
	GS-45 (GE240)	1.0446	
	GS-52 (GE260)	1.0552	
	GS-60 (GE300)	1.0558	
	35S 20	1.0726	
	9S 20	1.0711	
	9SMn 28	1.0715	
	9SMn 36	1.0736	
	9SMnPb 28	1.0718	
	9SMnPb 36	1.0737	
13Cr 3	1.7012		
16MnCr 5	1.7131		
C15	1.0401	5 ÷ 8	
CuSn 6	2.1093		
Stopy miedzi; Copper alloys	CuSn5	2.1096	
	CuZn40MnPb	2.0580	7 ÷ 11
	CuZn44Pb2	2.0410	

**Załącznik 1** Materiały obrabiane;  
**Attachment 1** Machined materials

Rodzaj materiału Type of material	Grupa; Group	Przedstawiciele wg DIN; Representative acc. to DIN		Prędkość skrawania; Cutting speed $V_c$ [m/min]
		Oznaczenie; Designation	DIN Nr; No	
Stale niestopowe; Unalloyed steels $R_m \leq 800$ N/mm <sup>2</sup>	1	St37-3	1.0116	10 ÷ 20 [m/min]  20 ÷ 50 [m/min] (dla gwintowników pokrytych; for coating taps)
		St52-3	1.0570	
		St60-2	1.0060	
		StE 255 (S255N)	1.0461	
		StE 460 (P460N)	1.8905	
		StE 500 (S500N)	1.8907	
		C10	1.0301	
		C22	1.0402	
		C35	1.0501	
		C40	1.0511	
		GS-38 (GE200)	1.0420	
		GS-45 (GE240)	1.0446	
		GS-52 (GE260)	1.0552	
		GS-60 (GE300)	1.0558	
		35S 20	1.0726	
		9S 20	1.0711	
		9SMn 28	1.0715	
		9SMn 36	1.0736	
		9SMnPb 28	1.0718	
		9SMnPb 36	1.0737	
13Cr 3	1.7012	10 ÷ 20 [m/min]  20 ÷ 50 [m/min] (dla gwintowników pokrytych; for coating taps)		
16MnCr 5	1.7131			
C15	1.0401			
Cf53	1.1213			
Ck45	1.1191			
Ck55	1.1203			
Ck60	1.1221			
15Cr 3	1.7015			
15CrMo 5	1.7262			
25CrMo 4	1.7218			
32CrMo 12	1.7361			
34Cr 4	1.7033			
35CrMo 4	1.2330			
35CrNiMo 6	1.6582			
40Mn 4	1.1157			
41Cr 4	1.7035			
42CrMo 4	1.7225			
47CrMo 4	1.2332			
C35 E	1.1181			
C45	1.0503			
C55	1.0535			
C60	1.0601			
Cf35	1.1183			
Ck22	1.1151			
Ck25	1.1158			
14NiCr 14	1.5752			
16MnCr 5	1.7131			
Ck15	1.1141			

Rodzaj materiału Type of material	Grupa; Group	Przedstawiciele wg DIN; Representative acc. to DIN		Prędkość skrawania; Cutting speed $V_c$ [m/min]
		Oznaczenie; Designation	DIN Nr; No	
Stale niestopowe i stopowe; Unalloyed and alloyed steels $R_m \leq 1200$ N/mm <sup>2</sup>	3	39CrMoV	1.8523	5 ÷ 20 [m/min]
		100 Cr 6	1.3505	
		25CrMo 4	1.7218	
		30CrNiMo 8	1.6580	
		32CrMo12	1.7361	
		34Cr 4	1.7033	
		40Mn4	1.1157	
		41CrMo 4	1.7223	
		42CrMo 4 V	1.7225	
		StE690 V	1.8931	
		StE960 V	1.8941	
		100Cr 6	1.2067	
		100MnCrW 4	1.2510	
		100V 1	1.2833	
		115CrV 3	1.2210	
		50CrV 4	1.8159	
		58CrV 4	1.8161	
		60WCrV 7	1.2550	
		90MnCrV 8	1.2842	
		S10-4-3-10	1.3207	
		X100 CrMoV 5 1	1.2363	
		X165 CrMoV 12	1.2601	
		X210 Cr 12	1.2080	
		X210 CrW 12	1.2436	
		X50 CrMoW 9 11	1.2631	
		35NiCrMo 16	1.2766	
		40CrMnMo 7	1.2311	
		45WCrV 7	1.2542	
		55NiCrMoV 6	1.2713	
		60NiCrMoV 12 4	1.2743	
		X30WCrV 5 3	1.2567	
		X30WCrV 9 3	1.2581	
		X32CrMoV 3 3	1.2365	
X36CrMo 17	1.2316			
X38CrMoV 5 1	1.2343			
X40CrMoV 5 1	1.2344			
X42Cr 13	1.2083			
14NiCr 14	1.5752			
16MnCr 5 V	1.7131			
17CrNiMo 6	1.6587			
17CrNiMo 6	1.6587			
31CrMo V 9	1.8519			
34CrNiMo 6	1.8550			
35CrNiMo 6	1.6582			
35CrNiMo 6	1.6582			
NiCr19 CoMo	2.4973			
X5NiCrTi 26 15	1.4980			
50CrV 4	1.8159			
56NiCrMoV 7	1.2714			
X155CrVMo 12 1	1.2379			
Stale niestopowe i stopowe; Unalloyed and alloyed steels $R_m \leq 1400$ N/mm <sup>2</sup>	4			3 ÷ 10 [m/min]

Rodzaj materiału Type of material	Grupa; Group	Przedstawiciele wg DIN; Representative acc. to DIN		Prędkość skrawania; Cutting speed $V_c$ [m/min]
		Oznaczenie; Designation	DIN Nr; No	
Stale nierdzewne i kwasoodporne; Stainless and acid resistand steels (V2A)	5	GX10CrNi 18 8	1.4312	2 ÷ 5 [m/min]
		GX20Cr 14	1.4027	
		GX5CrNi 19 10	1.4308	
		GX8CrNi 13	1.4008	
		X10Cr 13	1.4006	
		X10CrNiS 18 9	1.4305	
		X105CrMo 17	1.4125	
		X12CrMoS 17	1.4104	
		X12CrNi 17 7	1.4310	
		X12CrS 13	1.4005	
		X15Cr 13	1.4024	
		X2CrNi 18 9	1.4306	
		X2CrNiN 18 10	1.4311	
		X20Cr 13	1.4021	
		X20CrNi 17 2	1.4057	
		X22CrNi 17	1.4057	
		X10CrNiS 18 9	1.4305	
		X3CrNiN 17 8	1.4319	
		X30Cr 13	1.4028	
		X39Cr 13	1.4031	
		X46Cr 13	1.4034	
		X5CrNi 18 12	1.4303	
		X5CrNi 18 9	1.4301	
		X5CrNi 18 9	1.4350	
		X6CrAl 13	1.4002	
X6CrMo 17	1.4113			
X7Cr 13	1.4000			
X8Cr 17	1.4016			
Stale nierdzewne i kwasoodporne z podwyższoną zawartością chromu i niklu; Stainless and acid resistand steels with higher content of chrom and nikiel (V4A)	6	GX5CrNiMo 19 11	1.4408	10 ÷ 20 [m/min]
		GX5CrNiNb 19 10	1.4552	
		X1NiCrMoCuN 25 20 5	1.4539	
		X10CrNiTi 18 9	1.4541	
		X2CrMoTi 18 2	1.4521	
		X2CrNiMo 17 13 2	1.4404	
		X2CrNiMo 18 12	1.4435	
		X2CrNiMo 18 16	1.4438	
		X2CrNiMoN 17 12 2	1.4406	
		X2CrNiMoN 17 13 3	1.4429	
		X2CrNiMoN 22 5 3	1.4462	
		X3NiCrCuMoTi 27 23	1.4503	
		X4CrNiMoN 27 5 2	1.4460	
		X5CrNiCuNb 17 4	1.4542	
		X5CrNiMo 17 1	1.4401	
		X5CrNiMo 17 13	1.4449	
		X5CrNiMo 17 13 3	1.4436	
		X5CrNiNb 18 10	1.4546	
		X5NiCrMoCuNb 20 18	1.4505	
		X6CrNb 17	1.4511	
		X6CrNiMoTi 17 12 2	1.4571	
		X6CrNiNb 18 10	1.4550	
		X6CrTi 12	1.4512	
		X6CrTi 17	1.4510	
		X12CrNiMo 12	1.4939	



Rodzaj materiału Type of material	Grupa; Group	Przedstawiciele wg DIN; Representative acc. to DIN		Prędkość skrawania; Cutting speed $V_c$ [m/min]
		Oznaczenie; Designation	DIN Nr; No	
Stale nierdzewne i kwasoodporne; Stainless and acid resistand steels (V2A i V4A)	7	X5NiCrTi26-15	1.4980	10 ÷ 20 [m/min]
		X5CrNi 13 4	1.4313	
		GX30CrSi6	1.4710	
		X50CrMnNiNbN21-9	1.4882	
		X55CrMnNiN20-8	1.4875	
		X19CrMoNbVN11-1	1.4913	
		X14CrMoS17	1.4104	
		X4CrNiMo16-5-1	1.4418	
		X5CrNiCuNb16-4	1.4542	
		GXZ5CrNi13-4	1.4317	
		X20CrMo13	1.4120	
Stale szybko tnące; High speed steels	8	S12-1-4-5	1.3202	5 ÷ 20 [m/min]
		S18-0-1	1.3355	
		S18-1-2-10	1.3265	
		S18-1-2-5	1.3255	
		S2-10-1-8	1.3247	
		S2-9-1	1.3346	
		S2-9-2	1.3348	
		S2-9-2-8	1.3249	
		S5-5-3	1.3344	
		S6-5-2	1.3343	
		S6-5-2-5	1.3243	
		S7-4-2-5	1.3246	
		SC6-5-2	1.3342	

Rodzaj materiału Type of material	Grupa; Group	Przedstawiciele wg DIN; Representative acc. to DIN		Prędkość skrawania; Cutting speed $V_c$ [m/min]
		Oznaczenie; Designation	DIN Nr; No	
Żeliwo szare; Grey cast iron (GG)	9	GG10 (EN-GJL-100)	0.6010	10 ÷ 20 [m/min]
		GG15 (EN-GJL-150)	0.6015	
		GG20 (EN-GJL-200)	0.6020	
		GG25 (EN-GJL-250)	0.6025	
		GG30 (EN-GJL-300)	0.6030	
		GG35 (EN-GJL-350)	0.6035	
		GG40 (EN-GJL-400)	0.6040	
Żeliwo sferoidalne, żeliwo ciągliwe; Spheroidal cast iron, malleable cast iron (GGG, GT)	10	GGG40 (EN-GJS-400-25)	0.7040	20 ÷ 50 [m/min]
		GGG50 (EN-GJS-500-7)	0.7050	
		GGG60 (EN-GJS-600-3)	0.7060	
		GGG70 (EN-GJS-700-2)	0.7070	
		GGG80 (EN-GJS-800-2)	0.7080	
		GTS55-05	0.8055	
Żeliwo wermikularne; Wermikular cast iron (GGV, GJV, CGI)	11	GJV-300		20 ÷ 50 [m/min]
		GJV-400		
		GGV-30		
		GGV-40		
Aluminium, miedź, stopy miedzi; Aluminium, copper, copper alloys	12	Al99	3.0205	30 ÷ 50 [m/min]
		Al99,9	3.0305	
		Al99,9 R	3.0400	
		E-Al	3.0257	
		SF-Cu	2.0090	
		CuZn20 (Ms80)	2.0250	
		CuZn30 (Ms70)	2.0265	
		CuZn37	2.0321	
		G-CuSn 6 ZnNi	2.1093	
		G-CuSn 5 ZnPb	2.1096	
Stopy aluminium, stopy miedzi; Aluminium alloys, copper alloys	13	G-AISI 12	3.2581	30 ÷ 50 [m/min]
		G-AISI 10 Mg	3.2383	
		G-AISI 12 (Cu)	3.2583	
		G-AISI 5 Mg	3.2341	
		G-AISI 6 Cu	3.2151	
		G-AISI 7 Mg	3.2371	
		G-AISI 8 Cu 3	3.2161	
		G-AISI 9 Mg	3.2373	
		G-CuAl 10 Ni	2.0975	
		GD-AISI 12 (Cu)	3.2982	
		CuSn 6 Zn 6	2.1080	
Tworzywa termoplastyczne; Thermoplastics	14	Polyamid		20 ÷ 30 [m/min]
		Polystyrol		
		Polywinylochlorek		
		Ultramid		



Cantoni<sup>®</sup> GROUP **FENES<sup>®</sup>** S.A.

[www.fenes.com.pl](http://www.fenes.com.pl)

BOGATA OFERTA ASORTYMENTOWA;  
WIDE RANGE OF PRODUCTS

frezy, rozwiertaki;  
end mills, reamers

frezy, rozwiertaki, wiertła z węglików  
spiekanych;  
solid carbide tools

pogłębiacze, gwintowniki;  
countersinks and counterbores, taps

piły taśmowe do metali;  
band-saw blades for metal

piły taśmowe i trakowe do drewna;  
band-saw blades and gang saws for wood

piły tarczowe do drewna;  
circular saw blades for wood

narzędzia specjalne;  
special tools

**Fabryka Narzędzi Skrawających**

Cutting Tools Factory

ul. Kleeberga 2,

08-110 Siedlce, Poland



Regionalni Kierownicy Sprzedaży  
Region Warszawa: tel. kom. **603 757 222**  
Region Wrocław: tel. kom. **609 030 687**  
Region Katowice: tel. kom. **691 373 807**  
Region Poznań: tel. kom. **697 070 616**

Biuro Obsługi Klienta  
tel. +48 25 **632 50 83**  
tel. +48 25 **632 52 51**: w. **222, 324, 357, 365**  
fax +48 25 **632 79 46**  
e-mail: [sales@fenes.com.pl](mailto:sales@fenes.com.pl)

Serwis Techniczny  
tel. +48 25 **632 52 51** w. **394**

Customer Service Department  
ph./fax +48 25 **644 88 25**  
ph. +48 25 **632 52 51** ext. **227**  
fax +48 25 **632 79 46**  
e-mail: [export@fenes.com.pl](mailto:export@fenes.com.pl)  
e-mail: [dhs@fenes.com.pl](mailto:dhs@fenes.com.pl)